



TECHNICAL BULLETIN

Audco Ball Valve

Three Piece Floating Ball Valve 44 / 459 Series



Almost 40 years ago, AUDCO'S original 3-piece valve was responsible for the development of the BALL valve market in India. The Series 44 rapidly established itself as the industry standard for quality, reliability and long service.

As you would expect, Audco has developed and improved the Series 44 over the years to maintain its position as the DN8 - DN50 valve design which others strive to equal (see Page 9). Now, Audco's new, larger valve, the DN65 - DN150 Series 459, complements the Series 44 to offer you the most versatile, reliable and widely specified range of 3-piece ball valves available.

44/459 Valve Assembly

Gland nut

Does not need to be removed for actuator mounting thereby maintaining valve integrity

Anti-static stem design

Carbon Filled PTFE Thrust Seal and Packing Ensures the Electrical Continuity between Ball and Body

Seats

Wide range of seat materials to suit customer applications (see page 6)

Ball

316 stainless steel as standard with pressure equalising hole to balance cavity pressure with line pressure when valve is open.

Body seals

PTFE as standard for media compatibility but can be interchanged for alternative applications

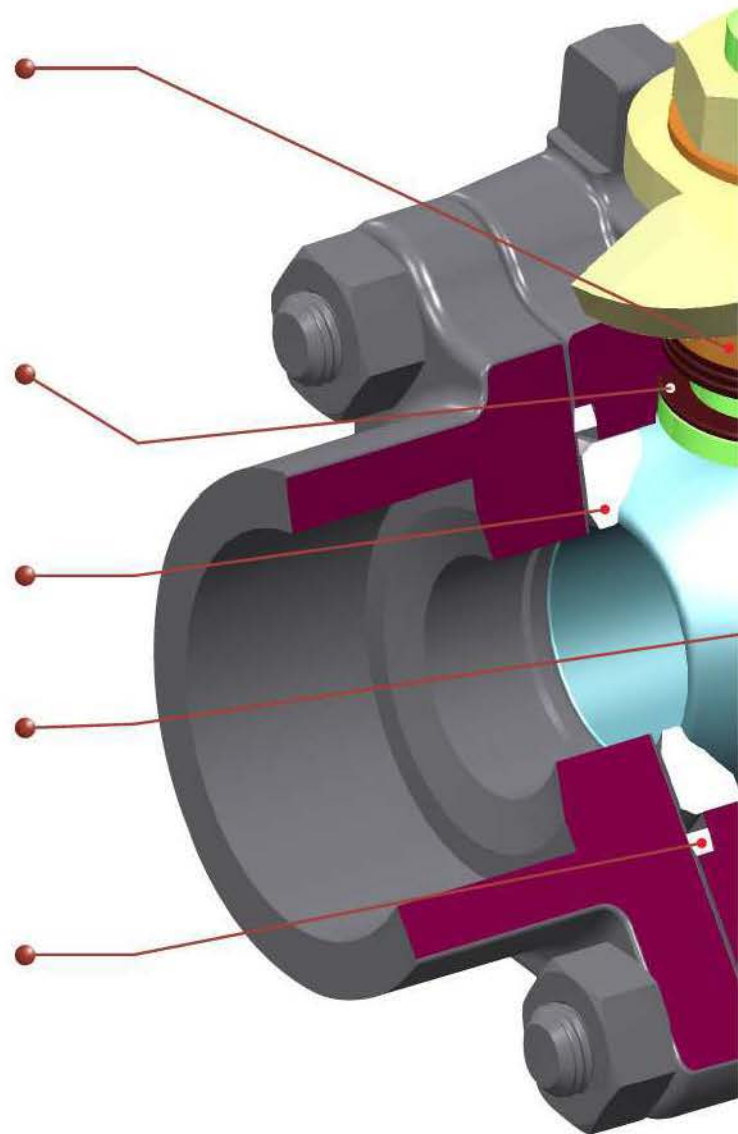

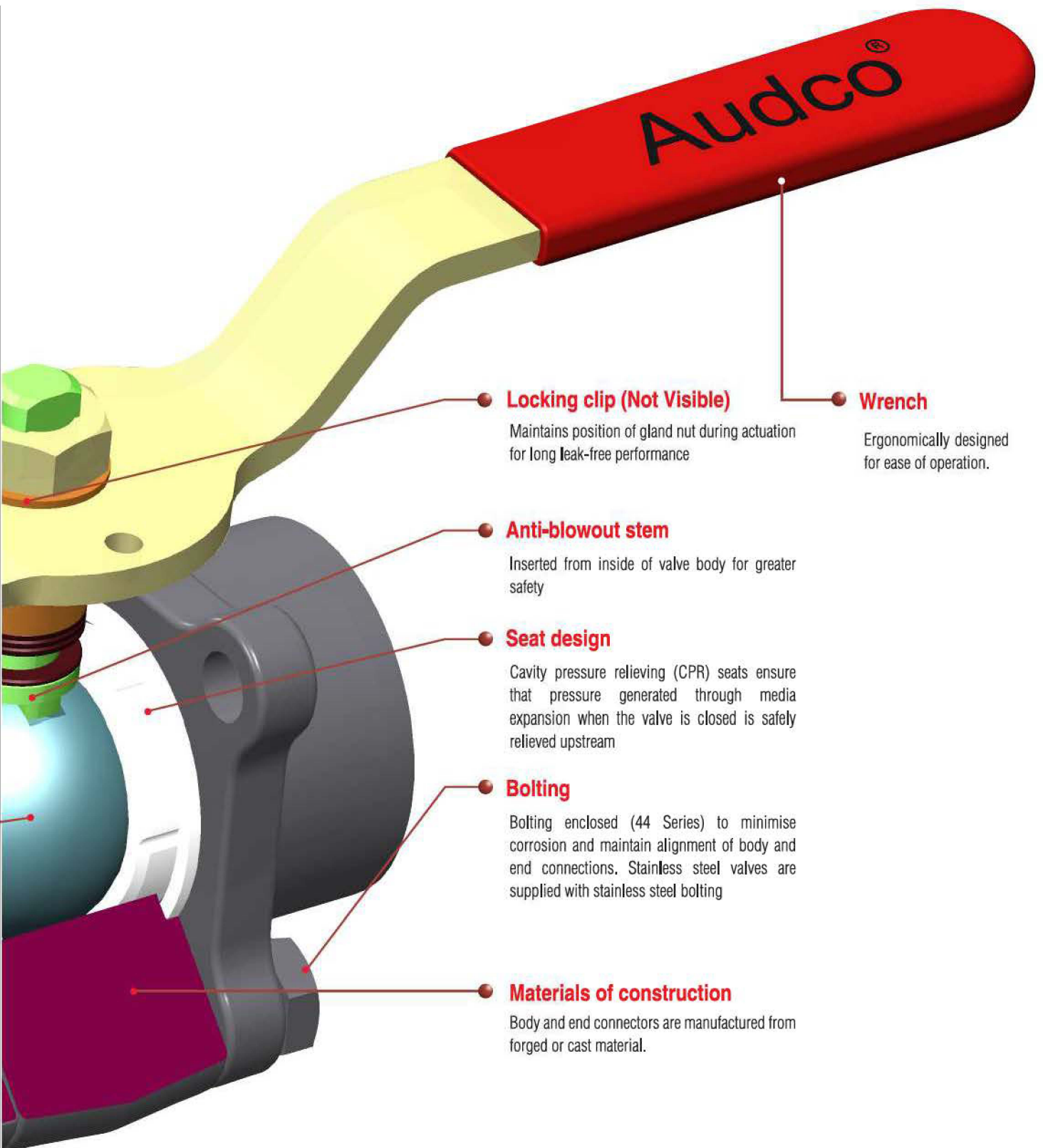

Locking clip (Not Visible)

Maintains position of gland nut during actuation for long leak-free performance

Wrench

Ergonomically designed for ease of operation.

Anti-blowout stem

Inserted from inside of valve body for greater safety

Seat design

Cavity pressure relieving (CPR) seats ensure that pressure generated through media expansion when the valve is closed is safely relieved upstream

Bolting

Bolting enclosed (44 Series) to minimise corrosion and maintain alignment of body and end connections. Stainless steel valves are supplied with stainless steel bolting

Materials of construction

Body and end connectors are manufactured from forged or cast material.

Three Piece Floating Ball Valve Parts

DN15 - DN50

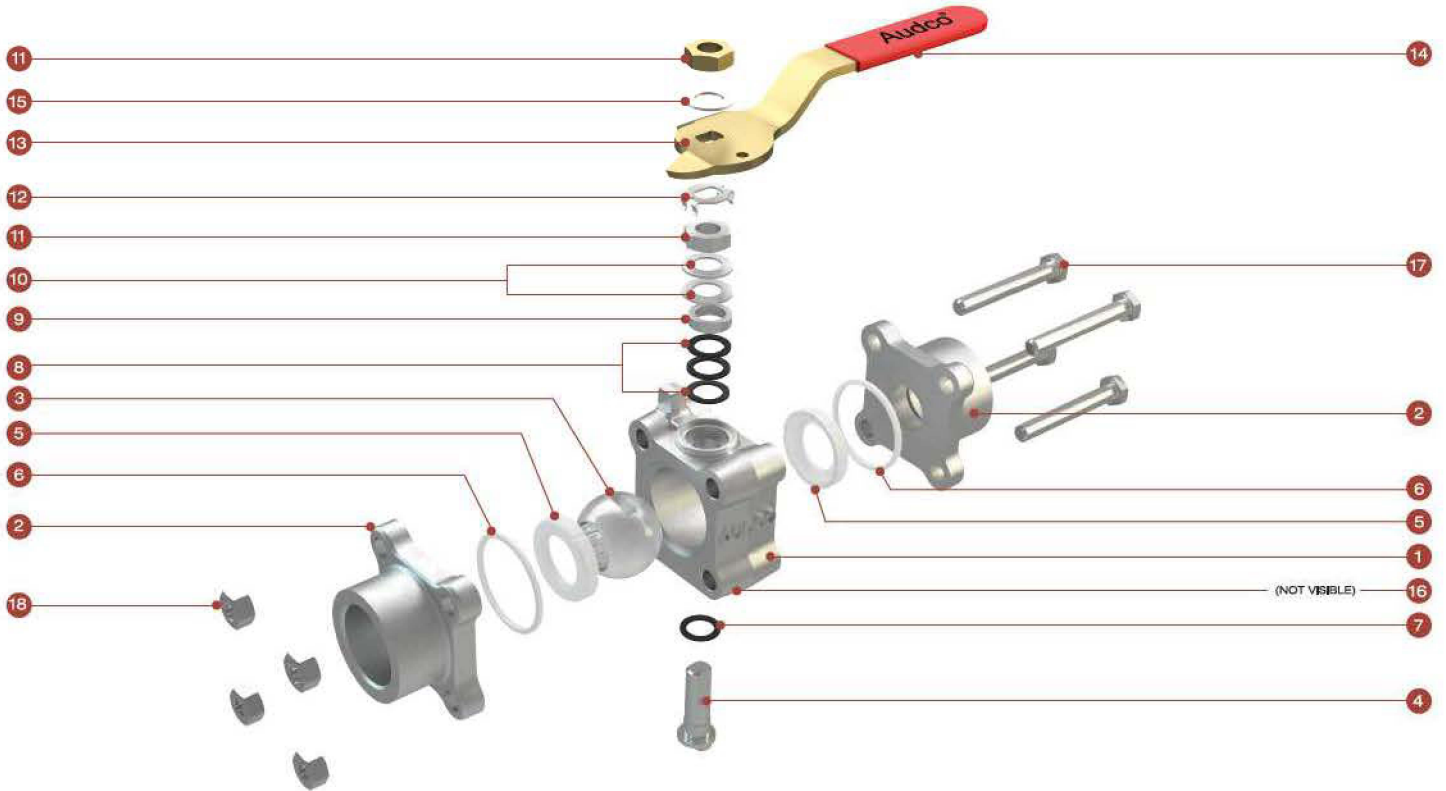

DN65 - DN150

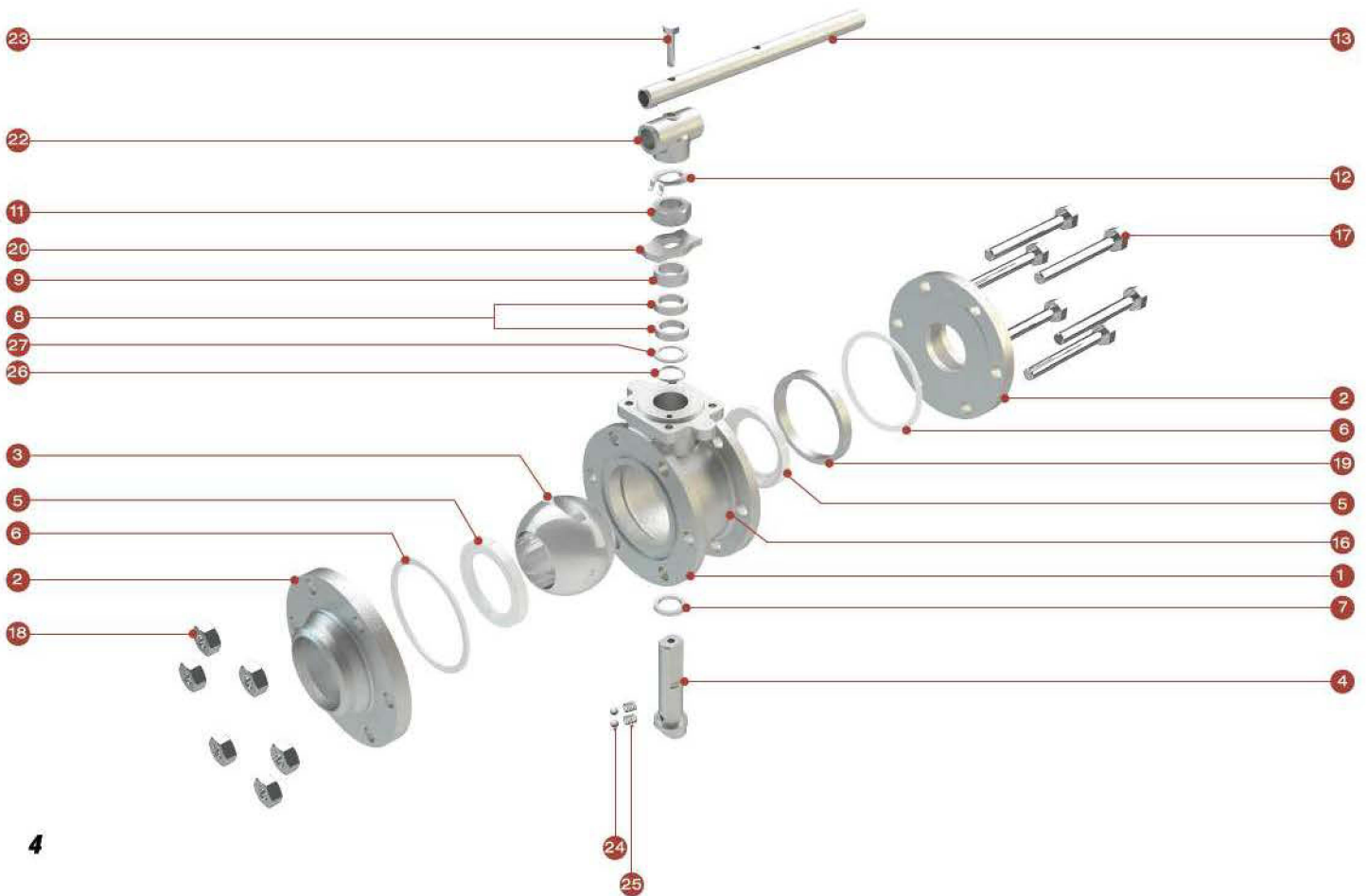

Parts/Materials List

ITEM & DESCRIPTION	DN8-DN50	DN65-DN150
1. BODY		
Stainless Steel ASTM A351 CF8M UNS J92900	•	•
Carbon Steel ASTM A105 UNS K03504	•	
Carbon Steel ASTM A350 LF2 UNS K03011		•
Carbon Steel ASTM A216 WCB UNS J03002	•	•
2. BODY CONNECTOR		
Stainless Steel ASTM A351 CF8M UNS J92900	•	
Carbon Steel ASTM A216 WCB UNS J03002	•	•
Carbon Steel ASTM A105 UNS K03504	•	
Carbon Steel ASTM A350 LF2 UNS K03011		•
3. BALL		
Stainless Steel ASTM A351 CF8M UNS J92900	•	•
Stainless Steel ASTM A479 316 UNS S31600	•	•
Stainless Steel ASTM A312 TP316L UNS S31603		•
4. STEM		
Stainless Steel ASTM A479 316 UNS 31600	•	•
Stainless Steel ASTM A564 Type 630, Condition H900 & H1150 UNS S17400	•	•
5.* SEATS (see also Pages 6)		
PTFE Virgin	•	•
PTFE 25% Glass Filled	•	•
PEEK	•	•
6.* BODY SEAL		
PTFE Virgin	•	•
Buna 'B'	•	•
Viton	•	•
7.* STEM THRUST SEAL		
PTFE 35% Carbon Filled	•	
PTFE 25% Glass Filled		•
PEEK	•	•
8. *GLAND PACKING		
PTFE 35% Carbon Filled	•	
Flexible Graphite		•
9. GLAND		
Stainless Steel	•	•
10. *DISC SPRINGS		
Stainless Steel	•	
Carbon Steel, Rust Proofed	•	
11. *GLAND/WRENCH NUT		
Stainless Steel	•	•
Carbon Steel, Rustproofed	•	•

ITEM & DESCRIPTION	DN8-DN50	DN65-DN150
12. *GLAND NUT LOCKING CLIP		
Carbon Steel, Rustproofed	•	•
13. WRENCH		
Stainless Steel	•	
Carbon Steel, Rustproofed	•	•
14. WRENCH SLEEVE		
Vinyl Plastisol	•	
15. SPRING WASHER		
Stainless Steel	•	
16. IDENTIFICATION PLATE		
Stainless Steel	•	•
17. BODY CONNECTOR BOLTS (see Note 1)		
Stainless Steel	•	•
Carbon Steel	•	•
18. BODY CONNECTOR NUTS		
Stainless Steel	•	•
Carbon Steel	•	•
19. SEAT RETAINING RING		
Carbon Steel		•
Stainless Steel		•
20. STOP INDICATOR		
Stainless Steel		•
Carbon Steel, Rustproofed		•
21. STOP PIN		
Stainless Steel 316	•	•
Carbon Steel, Rustproofed	•	•
22. WRENCH HEAD		
Malleable Iron, Rustproofed		•
23. WRENCH BOLT		
Stainless Steel		•
24. ANTI-STATIC PLUNGER		
Stainless Steel		•
25. ANTI-STATIC SPRING		
Stainless Steel		•
26. STEM LOCATION RING		
Stainless Steel		•
27.* SECONDARY STEM SEAL		
PTFE Virgin		•
Buna 'B'		•
Viton		•

Note 1: 4 bolts for valves up to DN50, 6 bolts DN65-80, and 8 bolts for DN100, 8 studs for DN150.
*Items marked thus denote components supplied in repair kit.

Pressure/Temperature Ratings

VIRGIN PTFE

Virgin PTFE is the most common sealing material and is suitable for almost all media as it has excellent chemical resistance.

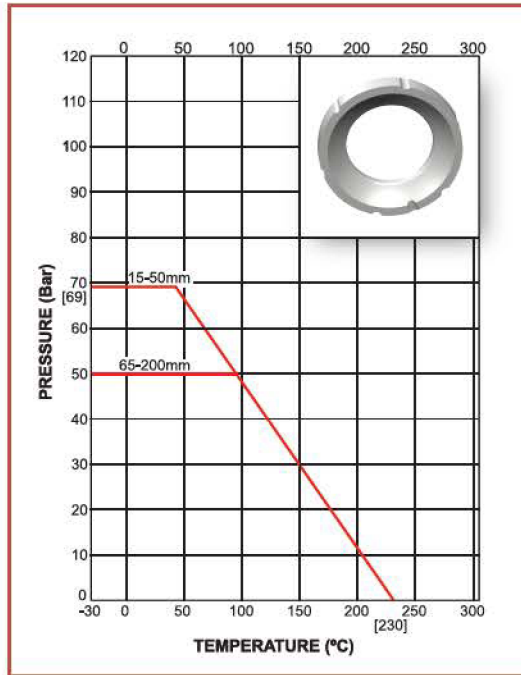

25% GLASS FILLED PTFE

Glass re-inforced PTFE material offering a greater pressure / temperature capability.

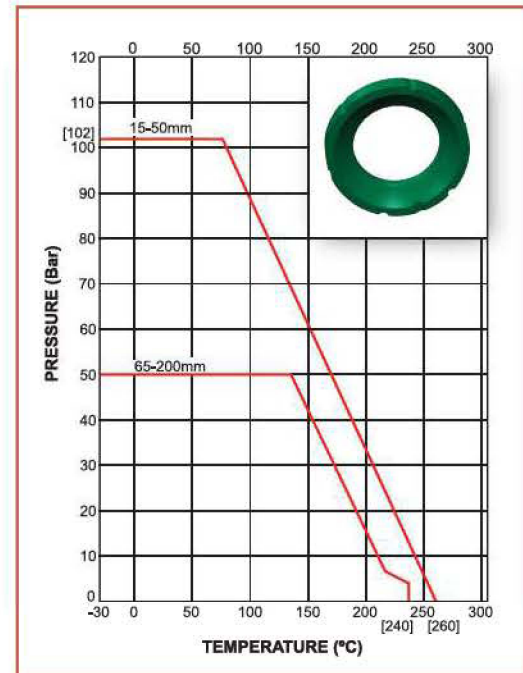

PEEK

PEEK is PolyEther Ether Ketone, a material which demonstrates outstanding pressure capabilities at elevated temperatures.

PEEK has excellent chemical and abrasion resistance

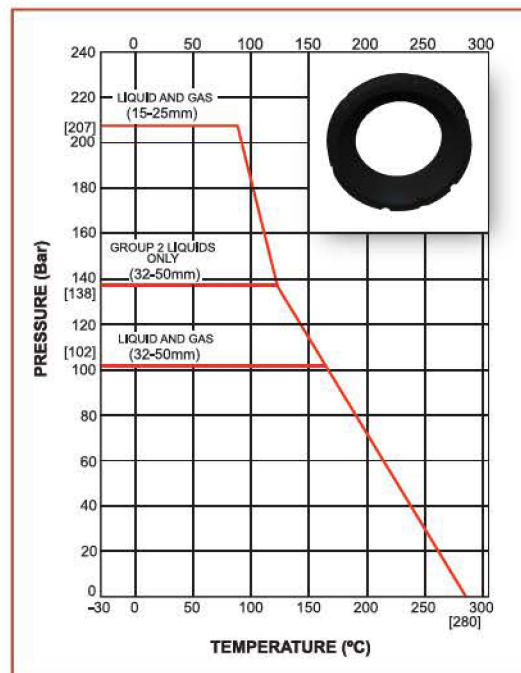

POLYFILL

Carbon, glass and graphite filled PTFE material, an excellent seat material for steam and thermal services. Due to its high cycling capabilities, it is the recommended soft seat for modulating control applications.

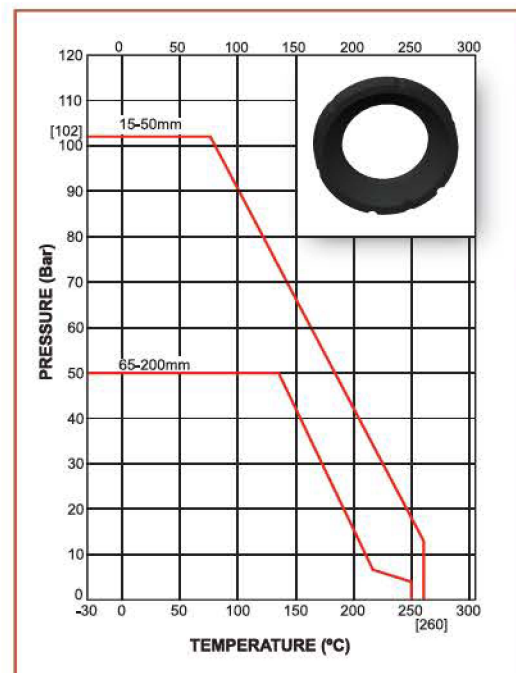

General Assembly

DN15 - DN50

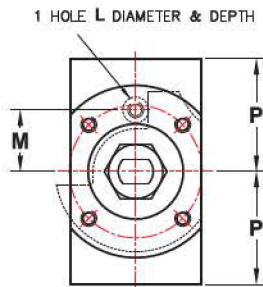

4 BOLT FIXING (DN32 - DN50)
ISO 5211 MOUNTING PATTERN
(SEE DIMENSION CHART)

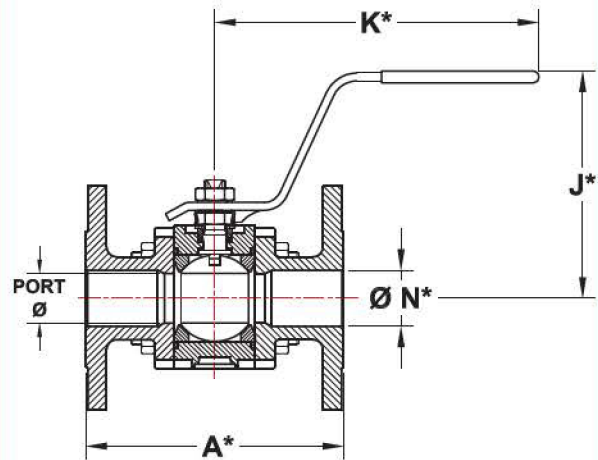

FLANGED END VALVE

* THUS MARKED DIMENSIONS ARE APPLICABLE TO CLASS 150 FLANGED END VALVES.
FOR OTHER DETAILS REFER SCREWED / SOCKET END DIMENSION TABLE GIVEN BELOW.

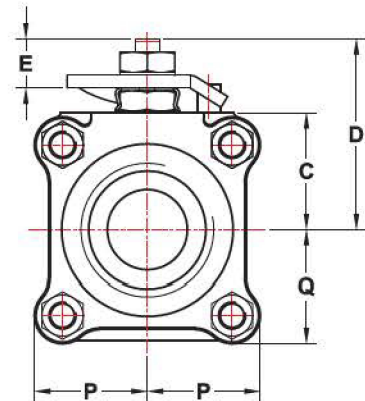
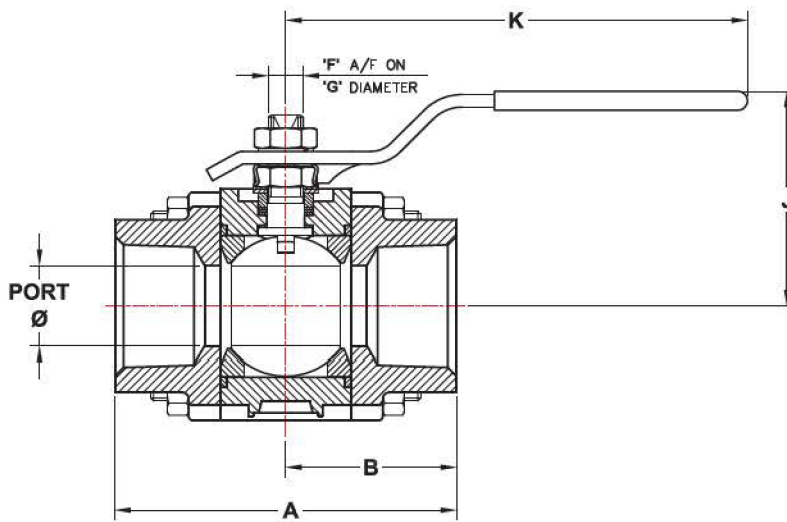

Valve Dimensions (mm)

VALVE SIZE (DN)	PORT Ø Min.	A	A*	B	C	D	E	STEM		J	J*	K	K*	L THREAD & DEPTH	M	ØN	P	Q	MOUNTING PLATFORM (ISO 5211)			WEIGHT (kg)	
								F A/F	G THREAD										ISO SIZE	MOUNTING HOLES	PLATFORM RECESS	Screwed & Socket	Flanged Class 150
15	11.2	64.9	108.0	32.5	-	37.9	10.6	5.54 5.46	3/8"-24 UNF	58.0	95.3	136.0	149.0	-	17.0	13.7	23.9	23.9	-	-	-	0.7	1.9
20	14.4	70.6	117.0	35.3	-	40.4	10.6	5.54 5.46	3/8"-24 UNF	61.0	97.8	136.0	149.0	-	19.0	20.0	25.9	25.9	-	-	-	0.9	2.4
25	20.7	93.3	127.0	46.6	-	55.6	15.5	7.54 7.47	7/16"-20 UNF	65.0	110.6	149.0	165.0	-	22.0	25.4	32.5	32.5	-	-	-	1.6	3.1
32	25.4	105.9	140.0	52.9	36.9	60.3	15.5	7.54 7.47	7/16"-20 UNF	70.0	115.3	149.0	165.0	M5x0.8p 6.0 MIN	19.5	32.0	35.7	35.7	F04	4 OFF M5x0.8p x7.5 DEEP MIN ON 42.0 P.C.D.	Ø30.15/30.02 x4.29/3.52 DEEP	2.2	4.3
40	31.8	114.2	165.0	57.0	43.8	73.1	19.5	8.71 8.64	9/16"-18 UNF	78.0	124.9	181.0	165.0	M6x1.0p 7.5 MIN	23.0	38.1	42.1	42.1	F05	4 OFF M6x1.0p x8.7 DEEP MIN ON 50.0 P.C.D.	Ø35.15/35.02 x4.01/3.26 DEEP	3.2	6.5
50	38.2	126.7	178.0	63.3	48.6	77.8	19.5	8.71 8.64	9/16"-18 UNF	83.0	129.6	181.0	190.0	M6x1.0p 8.7 MIN	23.0	51.0	46.9	46.9	F05	4 OFF M6x1.0p x8.7 DEEP MIN ON 50.0 P.C.D.	Ø35.15/35.02 x4.01/3.26 DEEP	4.3	9.2

General Assembly

DN65-DN150

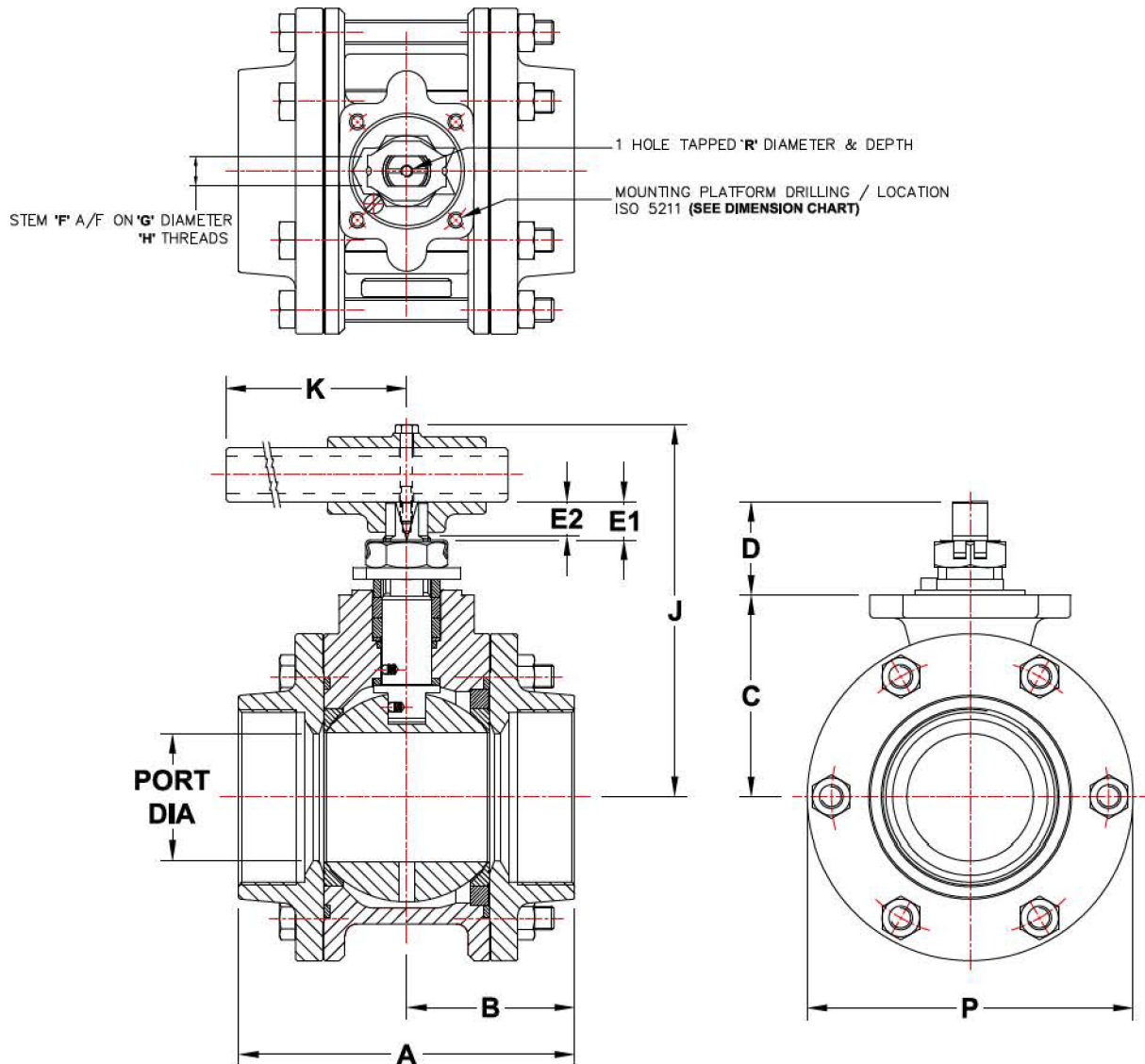

Valve Dimensions (mm)

VALVE SIZE (DN)	PORT Ø Min.	A	B	C	D	E MIN	E1 MIN	STEM			J	K	P Ø	R THREAD & DEPTH	MOUNTING PLATFORM (ISO 5211)		WEIGHT	
								F A/F	G Ø	H THREAD					ISO SIZE	MOUNTING HOLES		PLATFORM RECESS
65	50.8	149.74 148.11	74.46	87.57 86.87	43.83 41.50	13.15	-	14.0 13.9	-	M20x1.5p	156,1	225,0	148,0	M6x1.0p x10.0 MIN	F07	4OFFM8x1.25P ON 70.0 P.C.D.	Ø54.94 / 54.90 x3.0 / 2.6 HIGH	9.0
80	63.5	170.04 168.31	84.59	101.90 101.10	51.10 48.44	19.37	16.80	15.1 15.0	21.2 21.0	M24x2.0p	200,4	350,0	168,0	M6x1.0p x12.0 MIN	F07	4OFFM8x1.25P ON 70.0 P.C.D.	Ø54.97 / 54.90 x3.0 / 2.6 HIGH	13.3
100	76.2	214.67 212.94	106.9	119.90 119.10	55.70 53.04	21.67	21.00	19.3 19.2	27.2 27.0	M30x2.0p	213.5	557.0	169.0	M6x1.0p x12.0 MIN	F07	4OFFM8x1.5P ON 102.0 P.C.D.	Ø69.97 / 69.85 x3.0 / 2.6 HIGH	23.0
150	102.0	299.26 297.54	149.2	147.10 146.30	73.05 70.39	30.27	28.20	26.6 26.5	32.2 33.0	M36x2.0p	274,8	850,0	256,0	M8x1.25p x12.0 MIN	F07	4OFFM8x1.75P ON 125.0P.C.D.	Ø84.97 / 84.85 x3.0 / 2.6 HIGH	51.0

Standards of Compliance

Threaded Connections	Body connector screwed female to the following thread specifications: NPT ANSI B1.20.1 (NPT) BSPT ISO R/7.BS EN 10226-1 BSPP ISO R/7.BS EN ISO 228-1
Socket Weld	Body connectors bored suitable Connections for accepting plain end pipe to the following specifications: ASME B16.11, API 5L
Butt Weld Connections	Body connectors prepared in accordance with relevant material specification & ASME code section IX. For butt welding pipe to the following specifications: API 5L BS EN 10220 schedules 80/40/10/5
Pressure Test Specification	BS EN 12266 Part 1
Design Standard	BS EN ISO 17292 (BS 5351)

Notes:

1. When wrench not fitted flats on stem, when parallel to pipeline axis, denote ball open position.
2. All weld end valves are assembled with Buna 'O' ring body connector seals with the correct body seals supplied loose.
This provides for the valves to be tested by Audco, disassembled by the customer to weld in line, and reassembled.
Instructions will be supplied for fitting fire seals.
3. Limiting stem input torque figures are based on random practical laboratory tests.
4. For temperatures below -30°C, consult Audco.
5. Installation, Operating and Maintenance Instructions are available on request.

Flow Coefficients



Valve Size		Flow Coefficients		Equivalent Length of pipe	
mm	in	Cv	Kv	Feet	Metres
15	1/2	8.3	7.2	1.9	0.58
20	3/4	13.6	11.8	5.5	1.67
25	1	37.5	32.8	3	0.91
32	1¼	57	49.3	3.1	0.94
40	1½	79.7	69.1	3.9	1.19
50	2	106	91.8	7.5	2.28
65	2½	188	163	150	1.52
80	3	435	377	7	2.13
100	4	638	553	27	8.21
150	6	675	585	41	12.47

Cv - Flow in US EPM pressure - psi
Kv - Flow in m³/hr Pressure - bar

Limiting Stem Input Torque

Valve Size mm	Limiting Stem Input Torque (Nm)	
	316	17/4PH
15	13.2	90
20		
25	24.4	165
32		
40	48.6	268
50		
65	192	1187
80	336	1677
100	620	3540
150	1138	7758

Standards Valve Variants

<p>AW44</p> 	<p>Specifically designed for on/off steam applications in conditions up to 250psi (continuous saturated steam) or 1500 psi (thermal fluids), the AW44 is available in stainless or carbon steel in sizes from DN15-DN 50 (½"-2").</p>
<p>F44</p> 	<p>The F44 is particularly suitable for hazardous areas in hydrocarbon and chemical process lines, and is anti-static and firesafe to BS EN 12266 Part 2. It is available in stainless or carbon steel from DN15 - DN 50 (½"-2").</p>

How to Order

Valve Size	Operator	Bore	Product series	Body / Insert	Ball & Stem	Seats	Body Seal	Ends
05 - DN15	L - Lever / Wrench	R - Reduced bore* F - Full bore	44	4 - Carbon steel	4 - Carbon steel	T - PTFE	T - PTFE	AT - NPT
07 - DN20	G - Gear		F44	6 - 316 S.S	6 - 316 S.S	R - RPTFE	G - Graphite	BT - BSPT
10 - DN25	B - Bare stem for actuation		459			P - Polyfill		CT - Socket weld ends
12 - DN32	A - Actuator							F1 - ASME B16.5 CL.150
15 - DN40								F2 - ASME B16.5 CL.300
20 - DN50								
25 - DN65								
30 - DN80								
40 - DN100								
60 - DN150								

For any other additional requirement please specify. Please note that 44 & F44 series applicable up to DN50 only.

* - Reduced bore as a standard for 44 & F44 series. If full bore series is needed please specify.

Ordering Example:

A valve size DN25 Series 44 with Cast steel body and connector, 316 ball and stem, PTFE seats, seals and screwed NPT ends with Lever operated. For these requirements catalogue numbering shall be "10LR-4446TT-AT"

Salient Features

THREE-PIECE DESIGN

Ball Valves featuring this design are the most easily on-line maintainable in their class. By removing three body connector bolts and loosening the fourth, the body can be swung away using the fourth bolt as the fulcrum, to carry out any installation or maintenance operation on the valve. This feature reduces maintenance downtime to a bare minimum

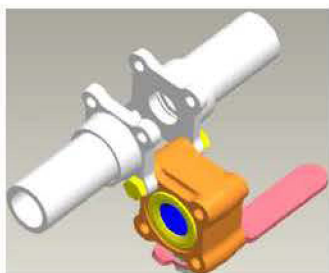

FIRE-SAFE FEATURE

AUDCO fire-safe design valves feature a secondary metal-to-metal seat which renders the valve fire-safe. An integral metal lip in the body and the configuration of the soft seat are designed to prevent the softening downstream seat from being forced into the port in the event of a fire. When the seat is totally sublimated in a fire, the ball moves and rests against the lip, forming a metal-to-metal seat, thus ensuring leak-tightness. End connectors or inserts have spigoted ends to ensure concentricity and correct alignment of the ball.

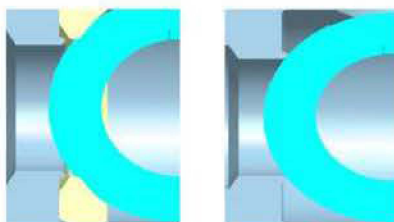

BEFORE FIRE

AFTER FIRE

MIRROR-FINISHED SS BALLS

The stainless steel balls are manufactured to very close sphericity tolerances and are mirror-finished. This results in bubble-tight sealing and considerably reduced operating torque.

CAVITY PRESSURE RELIEF

AUDCO's THREE PIECE BALL VALVES come with a built-in cavity relief seat design. This feature prevents overpressure in the ball cavity due to thermal expansion of the line fluid, and finds use in applications involving volatile line fluids. In principle, when cavity pressure builds up and reaches a certain magnitude, it causes the seat lip to move away from the ball relieving the pressure. Once the pressure has relieved the seat lip returns until the pressure builds up again. All valves have a hole connecting the ball port and the body cavity to prevent build-up of trapped cavity pressure when the valve is in open position.

ANTISTATIC FEATURE

Build-up of static electricity can result from rubbing of the ball against the PTFE seats. This can be a potential fire hazard, especially while handling inflammable fluids. All AUDCO Ball Valves are provided with built-in antistatic design features.

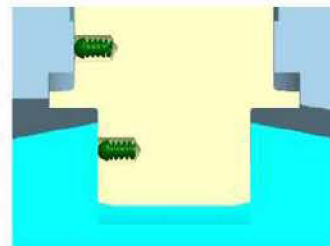

In general, this is achieved through 35% carbon-filled PTFE stem seals and Graphite gland packings to provide electrical continuity between the body and the stem / ball, discharging any build-up of static charge. In addition, spring-loaded plungers are provided between the stem and the ball from DN80 to DN150 (459 Series). Depending on the choice of seals, the designs also provide for additional spring-loaded plungers between the stem and the body for full mechanical antistatic capability.

MOULDED PTFE SEATS WITH SLOTS

PTFE seats are manufactured from moulded PTFE for a better grain structure compared to other methods of manufacture. Slots are provided in the seats to relieve the pressure past the upstream seat and prevent it from being forced against the ball. These features help lower operating torques, permit higher differential pressures and reduce wear, besides extending service life.

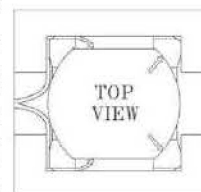

BLOW-OUT PROOF STEM

All AUDCO Ball Valves have a bottom-entry stem design which features stem insertion from inside the body. An integral shoulder on the stem sits against the shoulder in the body, giving it blowout proof integrity. The higher the line pressure, the tighter the seal. This design offers safety features superior to top-entry stem design where the line pressure works to break the stem seating (see illustration for typical three piece design).

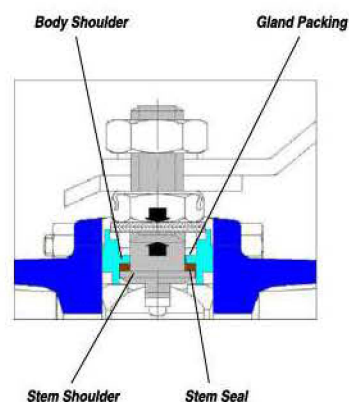



Flowserve India Controls Pvt Ltd,

B-8, CMDA Industrial Area,
Maraimalai Nagar - 603 209,
Kanchipuram Dist, Tamil Nadu, India.
(T) +91 44 27452323
(F) +91 44 24752327
Email: audcoplugindia@flowserve.com
audcoslimsealindia@flowserve.com

FCD MMNCAT0001-01 04/14.

To find your local Flowserve representative
or for more information about Flowserve Corporation,
visit www.flowserve.com

Flowserve Corporation has established industry leadership in the design and manufacture of its products. When properly selected, this Flowserve product is designed to perform its intended function safely during its useful life. However, the purchaser or user of Flowserve products should be aware that Flowserve products might be used in numerous applications under a wide variety of industrial service conditions. Although Flowserve can (and often does) provide general guidelines, it cannot provide specific data and warnings for all possible applications. The purchaser/user must therefore assume the ultimate responsibility for the proper sizing and selection, installation, operation, and maintenance of Flowserve products. The purchaser/user should read and understand the Installation Operation Maintenance (IOM) instructions included with the product, and train its employees and contractors in the safe use of Flowserve products in connection with the specific application.

While the information and specifications contained in this literature are believed to be accurate, they are supplied for informative purposes only and should not be considered certified or as a guarantee of satisfactory results by reliance thereon. Nothing contained herein is to be construed as a warranty or guarantee, express or implied, regarding any matter with respect to this product. Because Flowserve is continually improving and upgrading its product design, the specifications, dimensions and information contained herein are subject to change without notice. Should any question arise concerning these provisions, the purchaser/user should contact Flowserve Corporation at any one of its worldwide operations or offices.

© 2013 Flowserve Corporation, Irving, Texas, USA. Flowserve is a registered trademark of Flowserve Corporation.