

SPHERICAL DISC VALVE

Precised & Strong durable to 240° C / 600° C Temperature
And 10 Kg/cm² / 20 Kg/cm² Pressure

5 SPECIAL EFFECTS

1. COMPACT DESIGN - FULL PORT - OFFERS MASS FLOW
2. SIMPLE STRUCTURE, LIGHT & SMOOTH - TAKES VERY SHORT TIME FOR OPENING & CLOSING WITH VERY LOW TORQUE
3. EASY MAINTENANCE - REPLACEABLE SEALS DESIGN
4. SELF SEALING - SELF CLEANING - THE UNDER CUT DISC SEGMENT AND SEAL TENDS TO WIPE AWAY THE MATERIAL FROM THE SEALING AREA
5. GLAND PRESSING PLATE - ENSURES COMPLETE UTILIZATION OF GLAND SEALS

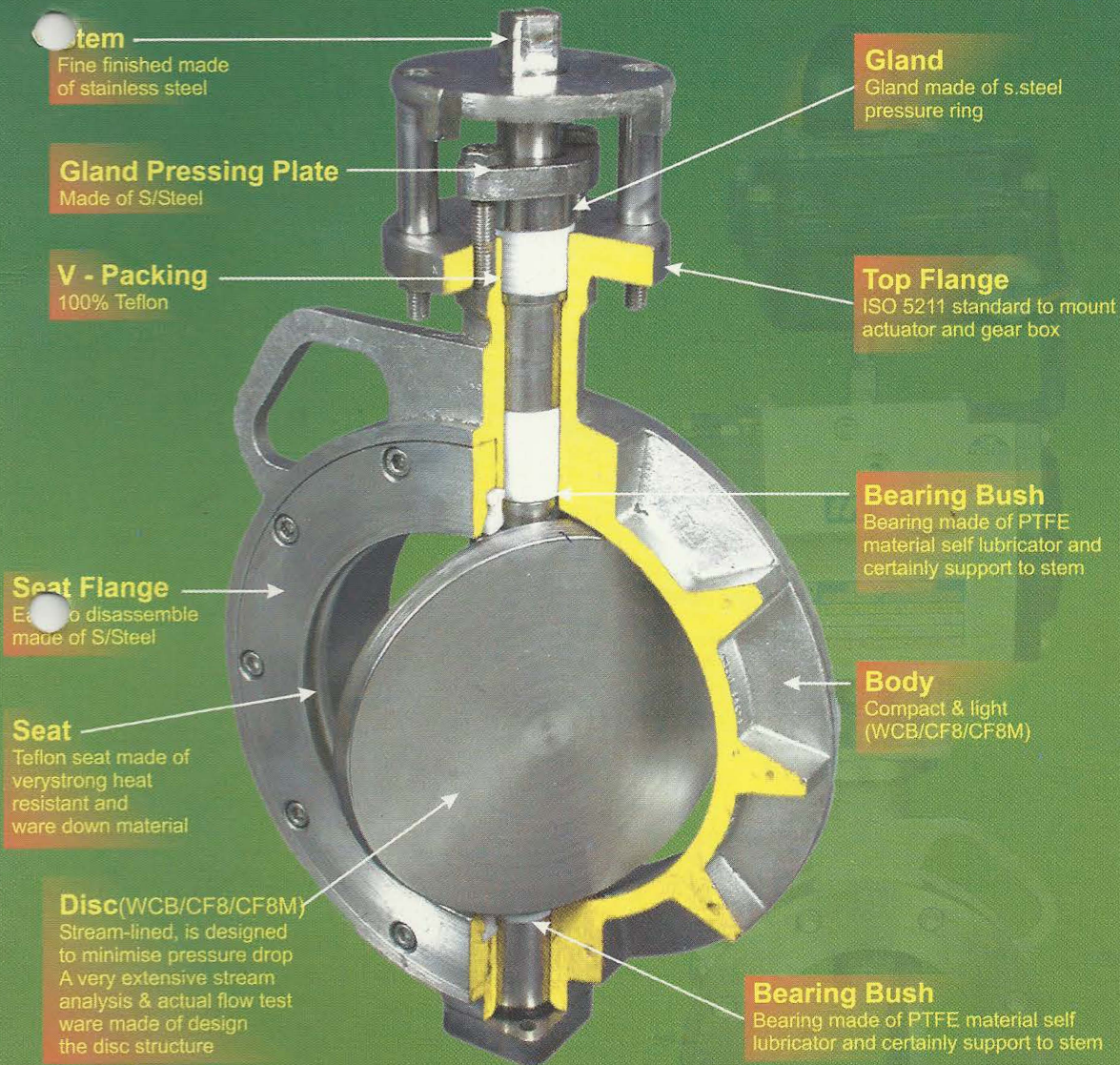

AVAILABLE
REPLACEABLE
SEALS



CARE
INDUSTRIAL VALVES

ISO 9001 CO.

 VALVE AUTOMATION ISO 9001:2000
 ISO 9001 CO. CERT. No. : 104504

aira
GROUP OF INDUSTRIES

SPHERICAL DISC VALVE

SIZE RANGE : 1½" TO 12" (14" TO 24" ON REQUEST)

APPLICATION



- Hygienic Powder & Slurries, especially in Pharmaceutical Industries.
- Chemicals and Dyeing Fluids in Textile Processing
- Brine Waters & Oils.
- Steam Lines, Air / Gas Lines.

SPHERICAL DISC VALVE HAS BEEN PROVED AS SUPERIOR TO OTHER VALVES IN MANY ASPECTS, PARTICULARLY IN

- ☒ WEIGHT
- ☒ SPACE
- ☒ PRESSURE RANGE
- ☒ MULTIPLE OPERATIONS
- ☒ MAINTENANCE EASE
- ☒ TORQUE & ECONOMY



COMPARISON WITH BALL VALVE & GATE VALVE

Model Item 150 NB (Valve Size)	Spherical Disc Valve	150# Ball Valve	150# Gate Valve
			
Pressure range - water	20 kgf / cm ²	19.3 kgf / cm ²	19.3 kgf / cm ²
Weight	12 Kg.	3 to 4 times Kg.	4 to 5 times Kg.
Torque	14 Kgf.m	25 Kgf.m	30 Kgf.m

TECHNICAL SPECIFICATIONS & DIMENSIONS

MATERIAL OF CONSTRUCTION

- Body : WCB/CF8/CF8m/Cast Iron
 Disc : WCB/CF8/CF8m/Cast Iron
 Seat : PTFE
 (available EPDM / Viton / Metal to Metal)
 Plate Mounting : NAMUR Standard
 Operation : Hand Lever Type,
 Worm Gear Box Type,
 Pneumatic Actuated,
 Electrical Actuated

Kv Values in m³/hr.

Size (In Inch)	Kv (M ³ / hr)
1.1/2" (40)	12
2" (50)	16
2.1/2" (65)	22
3" (80)	45
4" (100)	110
5" (125)	141
6" (150)	286
8" (200)	550
10" (250)	901
12" (300)	1390

Torque Values in Kgf.m

Size (In Inch)	Differential Pressure (AP)			
	5 kg/cm ²	10 kg/cm ²	15 kg/cm ²	20 kg/cm ²
1.1/2" (40)	0.8	1.0	1.2	1.5
2" (50)	0.9	1.2	1.5	1.7
2.1/2" (65)	2.0	2.2	2.5	3.0
3" (80)	3.4	3.9	4.2	7.0
4" (100)	4.5	5.0	6.0	7.0
5" (125)	6.5	7.0	7.5	9.0
6" (150)	9.0	10.0	12.0	14.0
8" (200)	16.0	18.0	20.0	22.0
10" (250)	23.5	25.8	27.5	30.0
12" (300)	32.0	36.0	40.0	48.0

DIMENSIONS:

VLV.SIZE	A	ØB	C	ØD	H	H1	L
1.1/2" (40)	42	38	59.5	50	144.5	85.5	190
2" (50)	45	51	68.5	60	163.5	145	190
2.1/2" (65)	48	60	74.5	72	188	165	190
3" (80)	48	72	80	85	200	170	250
4" (100)	54	100	95	110	228	195	250
5" (125)	57	123	117	135	268	220	250
6" (150)	57	143	132	152	300	235	250
8" (200)	64	192	157.5	200	356.5	250	340
10" (250)	72	239	184	250	408	301	340
12" (300)	81	290	210	300	475	350	340

All Dimensions are in (mm.)

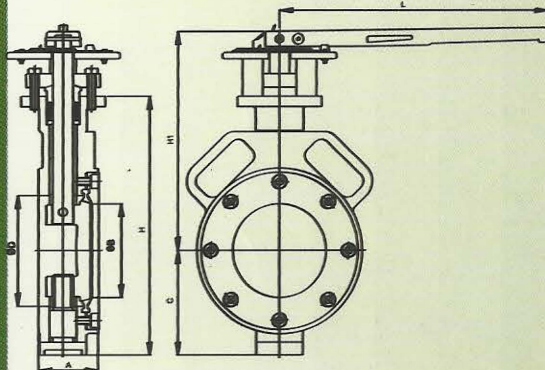

Note: Due to constant worldwide advancement in technology, we keep our rights reserved to make changes from time to time in Technical Specifications and Dimensions without prior notice.

SPHERICAL DISC VALVE WITH PNEUMATIC ROTARY ACTUATOR



aira PNEUMATIC ACTUATORS

SALIENT FEATURES

- Compact Design provides high torque values.
- Common body size for double acting & spring return.
- Pre-loaded spring cartridges, eliminate the danger in case of disassembly of spring return actuator thus interchanging of springs become quite easy.
- Innovative Sliding skates, between racks and internal bore of the actuator which enhances the life of actuator by preventing the metal to metal contact.

TECHNICAL SPECIFICATIONS

Air Supply	: Filtered, dry or lubricated
Operating Pressure	: 15 PSI to 150 PSI
Temperature Range	: -20°C to 90°C (High Temp. on request)
Mounting Standard	: ISO 5211 Standard
Pneumatic Connections	: NAMUR Standard
Accessories Mountings	: NAMUR Standard
Body Material	: Extruded Aluminum Alloy ASTM 6063
Racks	: Aluminum pressure die cast
Pinion	: En 8. Electro less nickle plated
End Caps	: Aluminum pressure die cast
Guides	: Low friction acetylic resin
Spring Cartridges	: Spring Steel, Powder Coated
Seals	: Nitrile (Buna-N) Rubber, (Viton, EPDM - On request)

DIMENSIONS:

VLV.SIZE	A	B	B1	C	H	H1	OE	OF
1.1/2" (40)	42	46	29.5	59.5	144.5	220	38	82
2" (50)	45	46	29.5	68.5	163.5	230	51	95
2.1/2" (65)	48	46	29.5	74.5	188	248.5	60	108
3" (80)	48	56	41.5	80	200	283	72	127
4" (100)	54	56	41.5	95	228	296	100	159
5" (125)	57	60	51	117	268	332	123	186
6" (150)	57	60	51	132	300	349	143	217
8" (200)	64	60	60	157.5	356.5	427	192	270
10" (250)	72	60	60	184	408	452	239	322
12" (300)	81	69.5	69.5	210	475	513	290	382

All Dimensions are in (mm.)

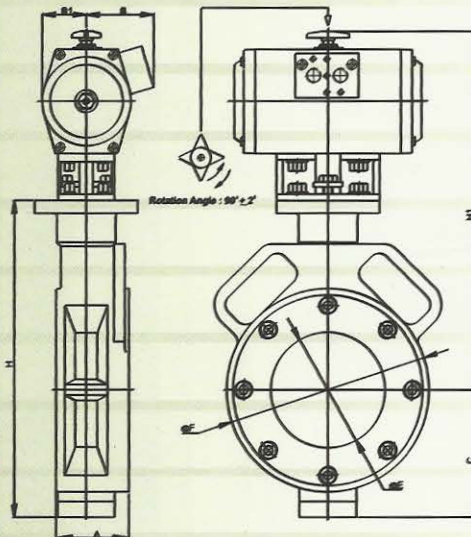

Note: Due to constant worldwide advancement in technology, we keep our rights reserved to make changes from time to time in Technical Specifications and Dimensions without prior notice.

CARE
INDUSTRIAL VALVES

Accessories



Adaptor Kit



Solenoid Valves



Manual Override



Position Indicator with Microswitch Box



Mounting Brackets & Adaptor



Filter + Regulator with Gauge

ISO 9001 CO.
aira
VALVE AUTOMATION
ISO 9001 CO.

SPHERICAL DISC VALVE WITH WORM GEAR ACTUATOR

Size : 8" to 12"

SALIENT FEATURES

- High torque capacities
- Adjustable travel stops
- Metallic compact housing
- Minimum friction

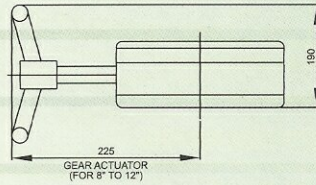

APPROVALS / PROMINENT CUSTOMERS



OTHER PRODUCTS

PRESSURE REDUCING VALVES • SAFETY VALVES • TAPER PLUG VALVES • SLUICE VALVES • REFLUX VALVES
PINCH VALVES • FOOT VALVES • MS BENDS (IBR APPROVED) • MS FLANGES (IBR APPROVED)
GM/SS HYDRANTS • ROTARY JOINTS • TUBE / SIGHT GLASS • NEEDLE VALVES • HYDRAULIC TEST PUMPS



BRANCH OFFICES & SHOWROOMS

Ahmedabad • Ankleshwar
Aurangabad • Baroda • Goa
Lucknow • Mumbai • Pune
Rajkot • Surat • Vapi

INTERNATIONAL OFFICE :- DUBAI

DEALERS NETWORK

Ahmednagar • Agra • Allahabad • Bangalore • Bhilai • Bhopal • Bhubhneswar
Chennai • Cochin • Coimbatore • Davangere • Gwalior • Hyderabad • Indore • Jaipur
Jamshedpur • Jodhpur • Kanpur • Karnal • Kolhapur • Korba • Kota • Nagpur
Raipur • Saharanpur • Secunderabad • Veraval • Vishakapatnam

MANUFACTURED BY :

Hawa Engineers Ltd.

AN ISO 9001 : 2000 Co.



Available at:

Dealer
TUBES & VALVES MFG CO
Ph:- 80120 1166
Email: - sales@tubesandvalves.com

For further details of other Products, visit our website