



Enriching Lives

KIRLOSKAR SWING CHECK TYPE REFLUX (NON RETURN) VALVES



KIRLOSKAR BROTHERS LIMITED

Applications

- Check valves are used in pipe lines to reduce water hammer and to prevent back flow of water to the pumps from rising mains
- These valves are suitable for handling clear water having turbidity of 3000 ppm maximum within the limits of the pressure ratings mentioned overleaf and for temperature upto 50 Deg.°C

Salient constructional features

- Swing check type double flanged design
- Rigid and sturdy design with minimum loss of head across the valve
- Perfect interchangeability of components
- Assured parallelism between side flanges
- Long service life and leak-tightness of high order

Material of construction					
	Body, Disc, Cover	Hinge	Hinge Pin	Body Ring	Disc Face
Standard Supply	Cast Iron	Cast Iron (Upto 300mm NB size) Carbon steel (Fab) above 350mm NB size	SS AISI 410	Leaded Gun Metal	Natural Rubber
Optional	Ductile Iron, Cast Steel	Ductile Iron, Cast steel	SS AISI 304 SS AISI 316 High Tensile Brass	SS AISI 316 SS AISI 304 SS AISI 410	Leaded Gun Metal SS AISI 304 SS AISI 410 SS AISI 316

For special material of construction please contact us.

End connection	
Standard Supply	BSEN 1092-2, PN10
Optional	BSEN 1092-2 PN 16 ANSI B16.1 CL125 ANSI B16.5 CL150 BS 10 TABLE- D / E / F

Accessories (optional)

- By pass arrangement
- Dashpot Arrangement (350mm NB & above sizes)
- Support foot
- Drain plug
- Strainer

Typical cross sectional view

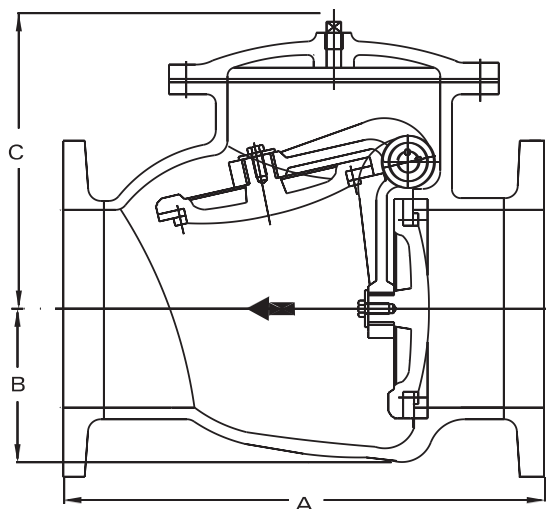

General dimensions

Normal Size (DN)	A (Basic Series 10)	A (Basic Series 48)	B Approx.	C Approx.
50	203	200	60	120
65	216	240	70	150
80	241	260	85	170
100	292	300	100	205
125	330	350	110	210
150	356	400	135	250
200	495	500	170	300
250	622	600	205	345
300	698	700	215	395
350	787	800	255	430
400	914	900	285	510
450	978	1000	320	570
500	978	1100	380	625
600	1295	1300	400	685

Hydraulic test pressure

Pressure Rating	Body Test Pressure	Seat Test Pressure
PN 6	9 kg/cm ²	6.6 kg/cm ²
PN 10	15 kg/cm ²	11.0 kg/cm ²
PN 16	24 kg/cm ²	17.6 kg/cm ²

Applications

- Multi-Door Non Return Valves are used in pipelines to reduce water hammer and to prevent back flow of water to the pump from rising mains. These valves are suitable for clear water having turbidity up to 5000 ppm and temperature upto 45°C

Salient constructional features

- Combination of excellent design features of reputed overseas valve brands.
- Rigid and sturdy design with minimum loss of head across the valve.
- Assured interchangeability between side flanges.
- Seat rings are fitted with special rivets and carefully machined to close tolerances.
- Long service life.

Material of construction			
	Body/Door/Diaphragm	Face/Seat Rings	Hinge Pin
Standard Supply	Cast Iron	Leaded Tin Bronze as per IS: 318, Gr. LTB2	Stainless Steel as per IS 1570
Optional Material	SG Iron as per IS:1865 2% NiCl Cast Steel as per ASTM-A216 Gr. WCB IS:1030	Stainless Steel As per IS: 6603 or IS: 1570 or ASTM A240	HT Brass/ Stainless Steel as per IS : 6603 / ASTM A-276

For special material of construction please contact us.

End connection	
Standard Supply	IS: 1538, Table 4 & 6.
Optional	BS 10, Table D/E/F BS EN1092.2(BS 4504), PN 10, PN 16 ANSI B16.1 IS: 6392

Accessories (optional)

- Bypass arrangement
- Companion flanges

Outline Dimensions

Sr. No.	Part No.	Description
1	108.0	Inlet Body
2	107.0	Outlet Body
3	129.0	Hinge Pin
4	615.0	Diaphragm
5	175.0	Door
6	581.1	Door Face Ring
7	581.2	Diaphragm Seat Ring
8	786.0	Stopper

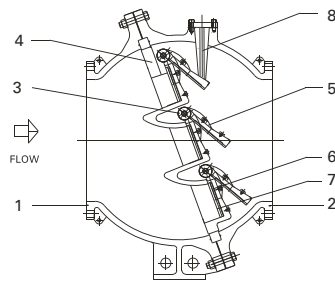

SECTIONAL VIEW FOR VALVE WITH 3 OR 4 DOORS

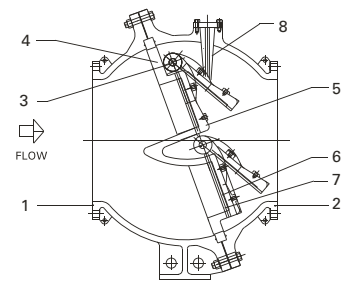

SECTIONAL VIEW FOR VALVE WITH 2 DOORS

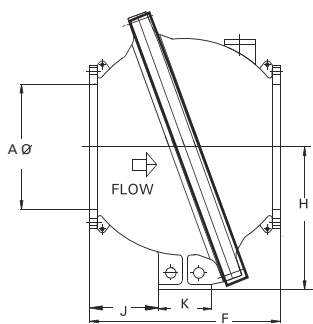

OUTLINE DIMENSIONS

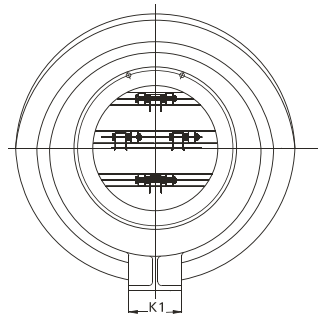

VIEW FROM OUTLET SIDE OF THE VALVE WITH 3 OR 4 DOORS

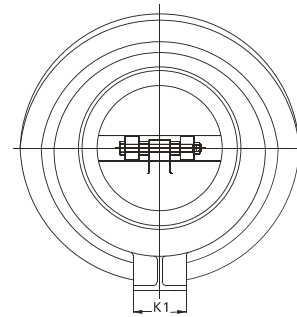

VIEW FROM OUTLET SIDE OF THE VALVE WITH 2 DOORS

General dimensions

Size A Dia	F	H	K	K1	J	Doors
600	914	685	254	254	330	02
700	1000	750	300	375	350	02
750	1045	750	300	375	375	02
800	1118	850	300	375	409	02
900	1250	915	300	375	475	03
1000	1250	915	300	375	475	03
1100	1396	1080	400	450	498	04
1200	1500	1175	400	450	550	04

Hydraulic test pressure

Rating	Max. Working Pressure (Bar)	Hydrostatic Test Pressure (Bar)		Test Duration (Minutes)
		Body	Seat	
PN 0.6	6	9	6	2
PN 1.0	10	15	10	2
PN 1.6 **	16	24	16	2

** : Pressure Rating PN 1.6 is beyond scope of the Standard IS:5312, Part-2. However KBL can supply valves with PN 1.6 rating against requirement.

OUR GLOBAL PRESENCE



As we are constantly endeavouring to improve the performance of our products / equipment, we reserve the right to make alterations from time to time and as such our products / equipments may differ from that detailed in this publication. For latest information you may get in touch with our Regional Sales Offices.



Enriching Lives

KIRLOSKAR BROTHERS LIMITED

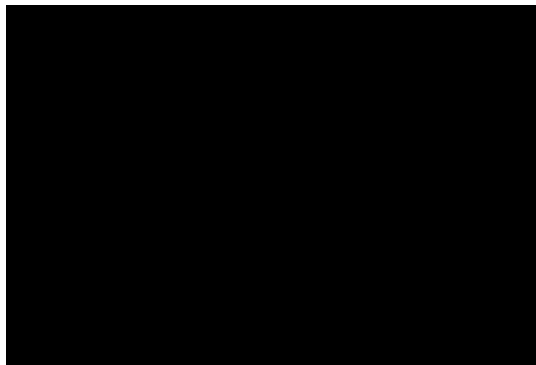

Dealer:-
TUBES & VALVES MFG CO,
Chennai,

Email :- sales@tubesandvalves.com

Ph:- +91 80120 11666

KIRLOSKAR BROTHERS LIMITED