

## BRONZE POP TYPE SAFETY VALVES

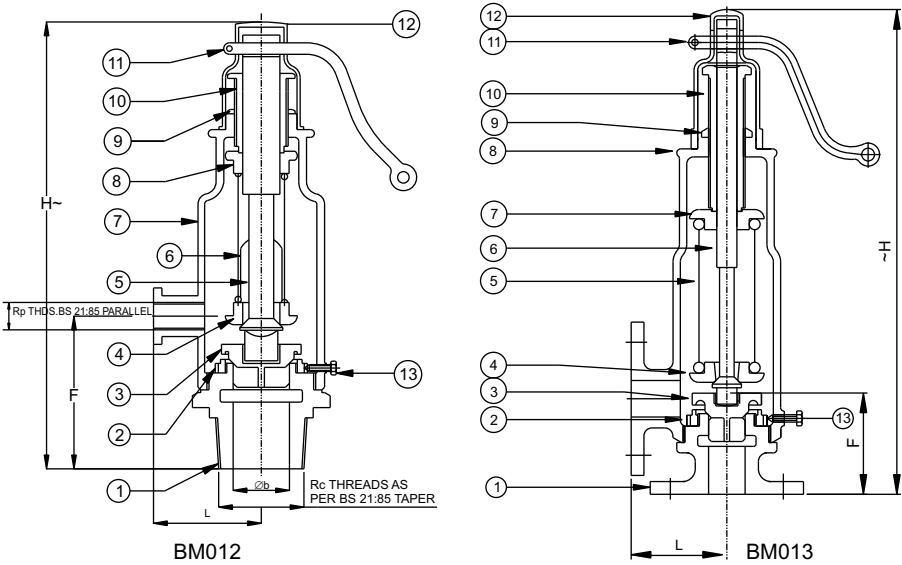

### STANDARD MATERIAL COMBINATION

P.NO.	QTY.	DESCRIPTION	MATERIALS	SPECIFICATIONS
1	1	BODY	BRONZE	IBR Clause 282 (a) (iv) Gr.B
2	1	ADJUSTING RING	BRONZE	IBR Clause 282 (a) (iv) Gr.B
3	1	VALVE DISC	BRONZE	IBR Clause 282 (a) (iv) Gr.B
4	1	LOWER SPRING DISC	BRONZE	IBR Clause 282 (a) (iv) Gr.B
5	1	SPRING	CARBON STEEL	IBR Clause 282 (a) (iv) Gr.B
6	1	STEM	H.T. BRASS	IBR Clause 307 to 314
7	1	UPPER SPRING DISC	BRONZE	IBR Clause 282 (a) (iv) Gr.B
8	1	CHAMBER	BRONZE	IBR Clause 282 (a) (iv) Gr.B
9	1	CHECK NUT	BRONZE	IBR Clause 282 (a) (iv) Gr.B
10	1	ADJUSTING SCREW	BRONZE	IBR Clause 282 (a) (iv) Gr.B
11	1	EASING LEVER	CARBON STEEL	-
12	1	STEM HOUSING CAP	ALUMINIUM	-
13	1	ADJUSTING RING FASTENER	BRASS	IS6912 Gr. FHTB1

### DIMENSIONAL DATA

NPS	1/2	3/4	1	1 1/4	1 1/2	2	2 1/2	3
H	285	305	305	405	405	455	495	515
L	45	64	64	66	66	86	108	121
F	72	84	84	111	111	114	114	145
Rp	1/2"	3/4"	1"	1 1/4"	1 1/2"	2"	2 1/2"	3"
Rc	3/4"	1"	1 1/4"	1 1/2"	2"	2 1/2"	3"	4"
Aprox. Wt. <sup>^</sup>								
Product Code Nos.	BM012 D	BM012 F	BM012 G	BM012 H	BM012 I	BM012 J	BM012 K	BM012 L
H1	285	305	305	405	405	455	495	515
L1	59	73	75	83	84	111	113	140
F1	67	73	75	83	84	111	110	140
Aprox. Wt. <sup>^</sup>								
Product Code Nos.	BM013 D	BM013 F	BM013 G	BM013 H	BM013 I	BM013 J	BM013 K	BM013 L

NOTE: The above data is subject to change without notice due to our continuing product improvement program. (<sup>^</sup>WEIGHT GIVEN IN KGS)

## BRONZE POP TYPE SAFETY VALVE

PRODUCT CODE NOS.		
PRODUCT	CODE NO.	END DETAILS
Pop type safety valve, Angle Pattern, Enclosed Discharge, Threaded Ends	BM012	Inlet: Screwed male BSP Taper Threads to BS 21 Outlet: Screwed female BSP parallel Threads to BS21
Pop type safety Valve, Angle Pattern, Enclosed Discharge, Flanged Ends	BM013	Flanges as per BS 10 Table F

TEST PRESSURES		
MAX. WORKING PRESSURE	SHELL TEST (HYDROSTATIC)	MAX. SET PRESSURES (STEM)
250 Psig (17.24 bar) at 435°F (225°C)	500 psig (34.5 bar)	250 psig (17.24 bar) at 435°F (225°C)

### APPLICATION

Pop type safety valves are meant for use on steam, air, gas or vapour service (i.e. for compressible fluids). The maximum set pressure for which these valves can be supplied is 250 psig (17.24 bar).  
Recommended maximum working temperature is 435°F (225°C)

### INSTALLATION

Pop type safety valves should be connected directly to the boiler nozzle super heater outlet connection or other vessels to which they are attached and in no case the area of such connection should be less than that of valve inlet. Any intervening piping is likely to cause chattering. Nor should a stop valve or other fitting be placed between the safety valve and pressure vessel outlet not in the discharge pipe between safety valve and atmosphere. Before mounting valve, all connections or piping must be carefully cleaned. Use very little pipe compound and only on male threads. Wrenches should be used with care so as not to distort the valve. Outlet piping should be as short as possible. If discharging against a constant back pressure, the valve must be set to compensate for the back pressure. Pop type safety valves should be operated regularly to ensure certainty of proper functioning. The disc may be lifted from its seat by means of easing lever. All valves should be installed with their spindles in vertical upright position.

### RELIEVING CAPACITIES

The relieving or discharge capacities of these valves at various set pressure are tabulated in capacity table.

TABLE I RELIEVING CAPACITIES								
Pop type safety valves for saturated steam at 10% accumulation								
Size at Inlet	1/2"	3/4"	1"	1 1/4"	1 1/2"	2"	2 1/2"	3"
Set Pressure kg/cm <sup>2</sup> g	KILOGRAMS OF STEAM PER HOUR AT SET PRESSURE							
1.0	20	46	82	128	185	329	514	740
2.0	29	68	122	191	276	491	767	1104
3.0	39	91	162	254	367	653	1020	1469
4.0	49	113	203	317	458	815	1273	1833
5.0	59	136	243	380	459	977	1526	2198
6.0	69	159	283	443	640	1139	1780	2562
7.0	79	181	324	506	731	1301	2033	2927
8.0	88	204	364	569	822	1463	2286	3291
9.0	98	227	405	632	914	1625	2539	3656
10.0	108	249	445	695	1005	1787	2792	4020
12.0	128	295	526	821	1187	2111	3299	4749
15.0	157	363	647	1010	1460	2597	4058	5843
17.57	183	421	751	1172	1695	3014	4709	6780

TABLE II RELIEVING CAPACITIES								
Pop type safety valves for air at 10% accumulation at inlet temperature at 15°C								
Size at Inlet	1/2"	3/4"	1"	1 1/4"	1 1/2"	2"	2 1/2"	3"
Set Pressure kg/cm <sup>2</sup> g	KILOGRAMS OF STEAM PER HOUR AT SET PRESSURE							
1.0	0.6	1.0	1.7	2.0	3.0	4.5	6.5	10.0
2.0	1.0	1.2	2.5	3.0	4.5	7.0	10.0	15.0
3.0	1.3	2.0	3.2	4.0	5.8	9.0	13.0	19.0
4.0	1.6	2.5	4.0	5.0	7.4	11.5	16.5	26.0
5.0	2.0	3.0	5.0	6.2	9.0	14.0	20.0	30.0
6.0	2.3	3.5	5.9	7.4	10.5	16.5	23.5	35.0
7.0	2.6	4.0	6.8	8.5	12.2	19.0	27.0	41.0
8.0	3.0	4.5	7.5	9.3	13.4	20.0	30.0	44.5
9.0	3.2	4.9	8.1	10.0	14.6	22.6	32.3	48.5
10.0	3.7	5.5	9.3	11.6	16.7	26.0	37.0	55.5
12.0	4.4	6.6	11.0	13.9	20.0	31.0	44.0	66.5
15.0	5.4	8.0	13.5	16.9	24.4	37.9	54.2	81.3
17.57	6.3	9.5	15.9	19.9	28.7	44.7	63.9	95.9

### INFORMATION REQUIRED WHILE ENQUIRING/ORDERING

- |  |   |
|--|---|
| <ol style="list-style-type: none"> <li>1. Size</li> <li>2. Item code no</li> <li>3. Fluid to be handled</li> <li>4. Set pressure</li> <li>5. Working temperature</li> <li>6. Maximum allowable over pressure</li> <li>7. Discharge capacity</li> </ol> | <ol style="list-style-type: none"> <li>8. End connections; if required other than standard.</li> <li>9. Whether flanges of flanged valves are required drilled or undrilled</li> <li>10. Scope of inspection if it is to be carried out at our works before despatch</li> </ol> |
|--|---|

NOTE: ITEMS CAN BE SUPPLIED WITH CERTIFICATE OF MANUFACTURE AND TEST OF FORM III C AS PER REGULATIONS 269 OF IBR

### MULTIPLYING FACTORS

Inlet temperature°C	Multiplier	Name of Gas	Multiplier
25	0.98	Natural Gas Sp. Gravity 0.60	1.142
40	0.96	Nitrogen	1.016
60	0.93	Oxygen	0.944
80	0.90	Carbon Dioxide	0.790
100	0.87	Butane	0.623
120	0.85	Ethane	0.870
160	0.81	Methane	1.190
180	0.80	Propane	0.176
220	0.76	Ethylene	0.900

NOTE: The above data is subject to change without notice due to our continuing product improvement program.

## BRONZE SPRING LOADED RELIEF VALVE

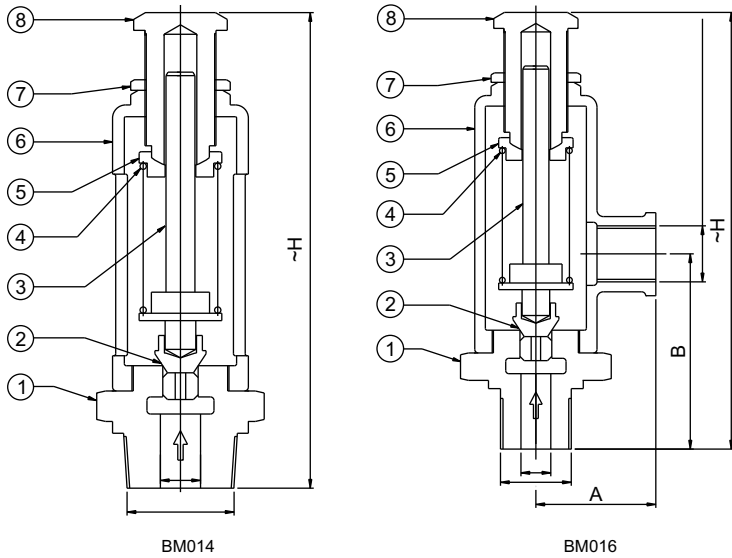

BM014



BM016

### STANDARD MATERIAL COMBINATION

P.NO.	QTY.	DESCRIPTION	MATERIALS	SPECIFICATIONS
1	1	BODY	BRONZE	EN 1982 Gr. CC491K
2	1	DISC	BRONZE	EN 1982 Gr. CC491K
3	1	STEM	BRASS ROD	DIN EN 12165:98 CW721R
4	1	SPRING	CARBON STEEL	IBR CLAUSE 307
5	1	SPRING DISC	BRONZE	EN 1982 Gr. CC491K
6	1	SPRING CHAMBER	BRONZE	EN 1982 Gr. CC491K
7	1	LOCKING NUT	BRONZE	EN 1982 Gr. CC491K
8	1	ADJUSTING SCREW	BRONZE	EN 1982 Gr. CC491K

### DIMENSIONAL DATA

NPS	1/2	3/4	1	1 1/4	1 1/2	2	2 1/2	3
H	140	153	178	195	222	246	375	464
Aprox. Wt. $\Delta$								
Product Code Nos.	BM014 D	BM014 F	BM014 G	BM014 H	BM014 I	BM014 J	BM014 K	BM014 L
H	140	153	178	195	222	246	375	464
A	35	41	45	51	57	70	81	95
B	56	66	70	79	94	100	116	130
Aprox. Wt. $\Delta$								
Product Code Nos.	BM016 D	BM016 F	BM016 G	BM016 H	BM016 I	BM016 J	BM016 K	BM016 L

### TEST PRESSURES

MAX. WORKING PRESSURE	SHELL TEST (HYDROSTATIC)	MAX. SET PRESSURE (WATER OR AIR)
150 psig (10.35 bar) Water or Air	300 psig (20.7 bar)	150 psig (10.35 bar)

NOTE: The above data is subject to change without notice due to our continuing product improvement program. ( $\Delta$ WEIGHT GIVEN IN KGS)

## BRONZE SPRING LOADED RELIEF VALVES

PRODUCT CODE NOS.		
PRODUCT	CODE NO.	END DETAILS
Bronze spring loaded Relief Valve, open Discharge, Threaded Inlet	BM014	Inlet : screwed male BSP Taper to Bs 21
Bronze spring loaded Relief Valve, Angle Pattern, Enclosed Discharge, Threaded Ends	BM016	Inlet: Screwed male BSP Taper Threads to BS 21 Outlet: Screwed female BSP paralld Threads to Bs21

### APPLICATION

Relief valves are meant for use on Liquid service (i.e. for incompressible fluids). The maximum set pressure for which these valves can be supplied is 150 psig (10.34 bar). Recommended maximum working temperature is 435°F (225°C).

These valves start opening at the set pressure & open in direct proportion to the increase in pressure over the set pressure. They require above 20% over pressure to open wide. As the pressure drops, they start to close and shut at approximately the set pressure.

### INSTALLATION.

Relief valves should always be installed as near as possible to the vessels they protect. They should be set at least 20 percent above the normal working pressure. Before installing relief valves, all particles of scale or dirt should be carefully removed from the pipe connection. When relief valves are installed on pipe lines, the valve should be one size smaller than the pipeline. When relief valves are installed where they are subject to back pressure on the outlet side, they should be fitted with a pressure tight cap over the adjusting screw in order to prevent leakage. If this is the requirement, it should be clearly stated in the enquiry or order.

All valves should be installed with their spindles in vertical upright position.

TABLE 1 RELIEVING CAPACITIES								
LIQUID RELIEF VALVES AT 25% OVER PRESSURE								
SIZE	½	¾	1	1 ¼	1 ½	2	2 ½	3
Set Pressure Kg/cm <sup>2</sup> g	CAPACITY IN KILOGRAMS PER HOUR OF WATER							
1.0	417	938	1669	2607	3755	6676	10431	18776
2.0	590	1327	2360	3688	5310	9441	14752	21243
3.0	708	1593	2832	4425	6372	11329	17702	25491
4.0	834	1877	3338	5215	7510	13352	20862	30042
5.0	933	2097	3731	5829	8396	14927	23324	41984
6.0	1021	2097	4088	6385	9197	16352	25550	45991
7.0	1103	2481	4415	6897	9934	17663	27597	49676
8.0	1179	2653	4720	7373	10620	18882	29503	53106
9.0	1251	2814	5007	7821	11265	20028	31293	56328
10.54	1353	3045	5418	8463	12190	21673	33864	60956

To obtain the discharge capacities at 20% over-pressure multiply the discharge capacity at 25% over-pressure by 0.97

### INFORMATION REQUIRED WHILE ENQUIRING/ORDERING

1. Size
2. Item code no.
3. Fluid to be handled
4. Set pressure
5. Working temperature
6. Maximum allowable over pressure
7. Discharge capacity.
8. End connections: if required other than standard.
9. Whether flanges of flanged valves are required drilled or undrilled.
10. Scope of inspection if it is to be carried out at works before despatch.

NOTE: The above data is subject to change without notice due to our continuing product improvement program.